

PWA_(M)D-1W5 & PWB_(M)D-1W5 Series 1.5W, WIDE INPUT, ISOLATED & REGULATED DUAL/SINGLE OUTPUT DC-DC CONVERTER

Patent Protection RoHS

FEATURES

- DIP package
- Wide input voltage range(4:1)
- Operating temperature: -40°C ~ +85°C
- 1500VDC Input/Output isolation
- Short circuit protection (automatic recovery)
- Internal SMD construction
- No external component required
- No heat sink required
- Industry standard pinout
- Five-sided shielding package(PWA/B_MD)
- MTBF>1,000,000 hours
- RoHS Compliance

APPLICATIONS

The PWA_(M)D-1W5 & PWB_(M)D-1W5 series are specially designed for applications where a wide range input voltage power supplies are isolated from the input power supply in a distributed power supply system on a circuit board.

These products apply to:

- 1) Where the voltage of the input power supply is wide range (voltage range≤ 4:1);
- 2) Where isolation is necessary between input and output (Isolation Voltage≤1500VDC);
- 3) Where the regulation of the output voltage and the output ripple noise are demanded.

MODEL SELECTION

PWA2412D-1W5

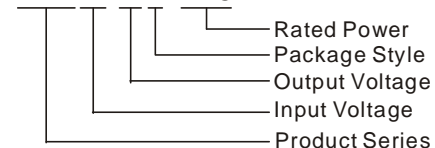

PRODUCT PROGRAM

Part Number	Input			No-load (mA)(typ.)	Output		Efficiency (%) (typ)					
	Voltage (VDC)				Voltage (VDC)	Current (mA)						
	Nominal	Range	Max*			Max		Min				
PWA2405D-1W5	24	9.0-36	40	16	±5	±150	±15	74				
PWA2412(M)D-1W5					±12	±63	±6	78				
PWA2415D-1W5					±15	±50	±5	79				
PWB2403(M)D-1W5					3.3	455	45	72				
PWB2405(M)D-1W5					5	300	30	74				
PWB2409MD-1W5					9	167	17	76				
PWB2412(M)D-1W5					12	125	12	78				
PWB2415MD-1W5					15	100	10	80				
PWA4805MD-1W5					48	18-72	80	8	±5	±150	±15	74
PWA4812D-1W5									±12	±63	±6	78
PWA4815(M)D-1W5	±15	±50	±5	80								
PWB4803(M)D-1W5	3.3	455	45	72								
PWB4805(M)D-1W5	5	300	30	74								
PWB4809(M)D-1W5	9	167	17	76								
PWB4812(M)D-1W5	12	125	12	78								
PWB4815(M)D-1W5	15	100	10	80								

Note:

1. Models listed with strike-through text have been officially discontinued.
- 2.* Input voltage over it may cause permanent damage to the device.

COMMON SPECIFICATIONS

Item	Test Conditions	Min.	Typ.	Max.	Units
Storage humidity				95	%
Operating temperature		-40		85	°C
Storage Temperature		-55		125	
Temp. rise at full load			15		
Lead temperature	1.5mm from case for 10 seconds			300	
Cooling	Free air convection				
Case material	D: Plastic(UL94-V0) , MD:Stainless steel				
Short circuit protection	Continuous, automatic recovery				
MTBF		1000			K hours
Weight			15		g

ISOLATION SPECIFICATIONS

Item	Test Conditions	Min.	Typ.	Max.	Units
Isolation voltage	Tested for 1 minute and 1mA max	1500			VDC
Isolation resistance	Test at 500VDC	1000			MΩ
Isolation capacitance	Input/Output, 100KHz/1V		100		pF

MORNSUN Science & Technology Co.,Ltd.

Address: No. 5, Kehui St. 1, Kehui development center, Science Ave., Guangzhou Science City, Luogang district, Guangzhou, P.R.China.

Tel: 86-20-38601850

Fax:86-20-38601272

[Http://www.mornsun-power.com](http://www.mornsun-power.com)

OUTPUT SPECIFICATIONS					
Item	Test Conditions	Min.	Typ.	Max.	Units
Output power	See above products program	0.15		1.5	W
Positive voltage accuracy	Refer to recommended circuit		±1	±3	%
Negative voltage accuracy	Refer to recommended circuit		±3	±5	
Load regulation	From 10% to 100% load		±0.5	±2*	
Line regulation	Input voltage from low to high		±0.2	±0.75	
Temperature drift	Refer to recommended circuit			±0.03	%/°C
Ripple**	20MHz Bandwidth		20	50	mVp-p
Noise**	20MHz Bandwidth		50	100	
Switching frequency	100% load, input voltage range		300		KHz

* Dual output models unbalanced load: ±5%.
 **Test ripple and noise by "parallel cable" method. See detailed operation instructions at Testing of Power Converter section, application notes.

TYPICAL CHARECTERISTICS

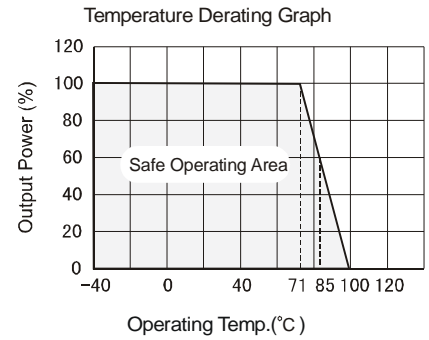

APPLICATION NOTE

RECOMMENDED CIRCUIT

1) Requirement On Output Load

In order to ensure the product operate efficiently and reliably, in addition to a max load (namely full load), a minimum load is specified for this kind of DC/DC converter. Make sure the specified range of input voltage is not exceeded, the minimum output load no less than 10% load. If the actual load is less than the specified minimum load, the output ripple may increase sharply while its efficiency and reliability will reduce greatly. If the actual output power is very small, please add an appropriate resistor as extra loading, or contact our company for other lower output power products.

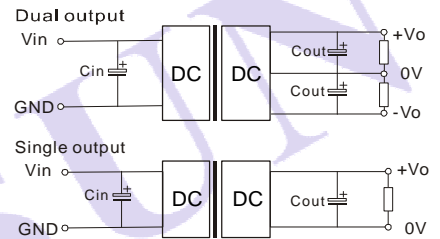

(Figure 1)

2) Recommended Circuit

All the PWA_(M)D-1W5 & PWB_(M)D-1W5 Series have been tested according to the following recommended testing circuit before leaving factory. (See Figure 1).

If you want to further decrease the input/output ripple, you can increase capacitance properly or choose capacitors with low ESR. However, the capacitance should not be too high, or may cause start-up problem. For every channel of output, provided the safe and reliable operation is ensured, the greatest capacitance of its filter capacitor sees (Table 1). If you want to use the products in high EMI, please choose our metal packaged products (PWA_MD-1W5 & PWB_MD-1W5). General:

Cin: 24V&48V 10μF~47μF
 Cout: 10μF/100mA

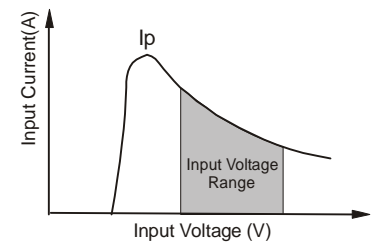

(Figure 2)

3) Input Current

When it is used in unregulated power supply, be sure that the fluctuating range of the power supply and the rippled voltage do not exceed the module standard. Input current of power supply should afford the startup current of this kind of DC/DC module. (See figure 2)

General: $I_p \leq 1.4 * I_{in-max}$

Output External Capacitor Table (Table 1)

Single Vout (VDC)	Cout (uF)	Daul Vout (VDC)	Cout (uF)
3.3	2200	±5	680
5	1000	±12	330
9	680	±15	220
12	470	-	-
15	330	-	-

4) No parallel connection or plug and play

OUTLINE DIMENSIONS & FOOTPRINT DETAILS

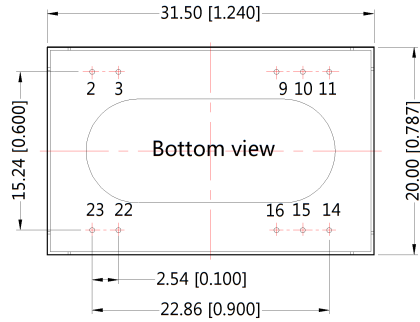
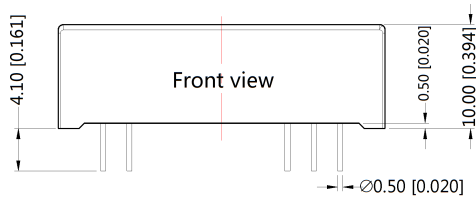

Note:
 Unit :mm[inch]
 Pin diameter tolerances:±0.10[±0.004]
 General tolerances:±0.50[±0.020]

THIRD ANGLE PROJECTION

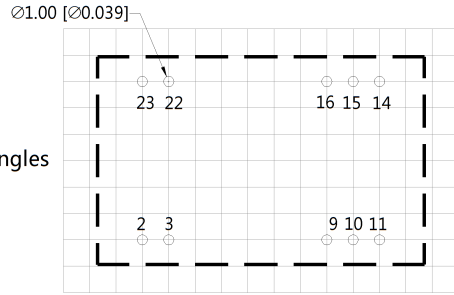

Note:Grid 2.54*2.54mm

Pin-Out		
Pin	Single	Dual
2, 3	GND	GND
9	NC	0V
10,15	NC	NC
11	NC	-Vo
14	+Vo	+Vo
16	0V	0V
22,23	V in	V in

NC: No connection

Note:

1. The load shouldn't be less than 10%, otherwise ripple will increase dramatically.
2. Operation under 10% load will not damage the converter; However, they may not meet all specification listed.
3. All specifications measured at Ta=25°C, humidity<75%, nominal input voltage and rated output load unless otherwise specified.
4. In this datasheet, all the test methods of indications are based on corporate standards.
5. Only typical models listed, other models may be different, please contact our technical person for more details.