

WRE_CKS-1W & WRF_CKS-1W Series 1W, WIDE INPUT, ISOLATED & REGULATED DUAL/SINGLE OUTPUT SIP DC-DC CONVERTER

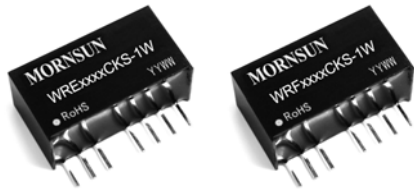

Patent Protection RoHS

FEATURES

- Efficiency up to 80%
- 2:1 wide input range
- 3000VDC isolation
- Short circuit protection (automatic recovery)
- External On/Off control
- Operating temperature range: -40°C to +85°C
- UL94-V0 Package

APPLICATIONS

The WRE_CKS-1W & WRF_CKS-1W series are designed for application where a wide input voltage range, isolated output is required from a distributed power system. For these DC-DC converters, You can reduce the design point of failure and save the development of micro power supply's manpower, material and time costs, also better ensure product quality stability, protect safety and reliability of the end of products.

These products apply to where:

- 1) Input voltage range ≤ 2:1;
- 2) 3KVDC input and output isolation;
- 3) Regulated and low ripple noise is required.

PART NUMBER SYSTEM

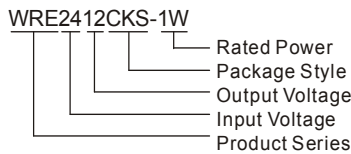

SELECTION GUIDE

Model Number	Input Voltage(VDC)		Output Voltage (VDC)	Output Current (mA)		Input Current (mA)(typ.)		Reflected Ripple Current (mA,typ.)	Max. Capacitive Load# (μF)	Efficiency (% , typ.) @Max. Load
	Nominal (Range)	Max*		Max.	Min.	@Max. Load	@No Load			
WRE0505CKS-1W	5 (4.5-9.0)	11	±5	±100	±10	278	50	35	680	72
WRE0512CKS-1W			±12	±42	±4	270			330	74
WRE0515CKS-1W			±15	±33	±3	274			220	73
WRF0505CKS-1W			5	200	20	286			1000	70
WRF0509CKS-1W			9	111	11	282			680	71
WRF0512CKS-1W			12	83	8	263			470	76
WRF0515CKS-1W			15	67	7	267			330	75
WRE1205CKS-1W	12 (9.0-18)	22	±5	±100	±10	109	20	30	680	76
WRE1212CKS-1W			±12	±42	±4	113			330	74
WRE1215CKS-1W			±15	±33	±3	111			220	75
WRF1203CKS-1W			3.3	303	30	113			2200	74
WRF1205CKS-1W			5	200	20	109			1000	76
WRF1209CKS-1W			9	111	11	107			680	78
WRF1212CKS-1W			12	83	8	105			470	79
WRF1215CKS-1W			15	67	7	104			330	80
WRE2405CKS-1W	24 (18-36)	40	±5	±100	±10	54	10	55	680	78
WRE2412CKS-1W			±12	±42	±4	54			330	78
WRE2415CKS-1W			±15	±33	±3	55			220	76
WRF2403CKS-1W			3.3	303	30	58			2200	70
WRF2405CKS-1W			5	200	20	55			1000	72
WRF2409CKS-1W			9	111	11	54			680	76
WRF2412CKS-1W			12	83	8	52			470	76

Model Number	Input Voltage(VDC)		Output Voltage (VDC)	Output Current (mA)		Input Current (mA)(typ.)		Reflected Ripple Current (mA,typ.)	Max. Capacitive Load [#] (μF)	Efficiency (%. typ.) @Max. Load
	Nominal (Range)	Max*		Max.	Min.	@Max. Load	@No Load			
WRF2415CK-1W	24 (18-36)	40	15	67	7	52	10	55	330	80
WRF2424CK-1W			24	42	4	54			220	72
WRE4805CK-1W	48 (36-72)	80	±5	±100	±10	28	5	382	680	76
WRE4812CK-1W			±12	±42	±4	27			330	77
WRE4815CK-1W			±15	±33	±3	28			220	75
WRF4803CK-1W			3-3	303	30	29			2200	72
WRF4805CK-1W			5	200	20	28			1000	76
WRF4809CK-1W			9	111	11	27			680	78
WRF4812CK-1W			12	83	8	26			470	80
WRF4815CK-1W			15	67	7	26			330	80

Note: 1. *Input voltage can't exceed this value, or will cause the permanent damage.
2. # For each output.
3. Models listed with strike-through text have been officially discontinued.

INPUT SPECIFICATIONS

Item	Test Conditions	Min.	Typ.	Max.	Unit
Input Surge Voltage (1sec. max.)	5VDC input	-0.7	--	12	VDC
	12VDC input	-0.7	--	25	
	24VDC input	-0.7	--	50	
	48VDC input	-0.7	--	100	
Short Circuit Input Power		--	1	--	W
Input Filter	Capacitance Filter				

OUTPUT SPECIFICATIONS

Item	Test Conditions	Min.	Typ.	Max.	Unit
Output Power		0.1	--	1	W
Positive voltage accuracy	Refer to recommended circuit	--	±1	±3	%
Negative voltage accuracy		--	±3	±5	
Output Voltage Balance	Dual Output, Balanced Loads	--	±0.3	±0.5	
Line Regulation	Full load, Input voltage from low to high	--	±0.2	±0.5	
Load Regulation	10% to 100% load	WRE_CKS-1W	--	±0.75	
		WRF_CKS-1W	--	±0.5	±0.75
Transient Recovery Time	25% load step change	--	8	10	ms
Transient Response Deviation		--	±3	±5	%
Temperature Drift	100% load	--	--	±0.03	%/°C
Ripple & Noise*	20MHz Bandwidth	--	25	75	mVp-p
Short Circuit Protection	Continuous, automatic recovery				

Note: 1. Dual output models unbalanced load: ≤5%.
2. *Test ripple and noise by "parallel cable" method. See detailed operation instructions at Testing of Power Converter section, application notes.

COMMON SPECIFICATIONS

Item	Test Conditions	Min.	Typ.	Max.	Unit
Isolation Voltage	Tested for 1 minute and 1mA max	3000	--	--	VDC
Isolation Resistance	Test at 500VDC	1000	--	--	MΩ
Isolation Capacitance	Input/Output, 100KHz/0.1V	--	35	--	pF
Switching Frequency	Full load, nominal input	--	300	--	KHz
MTBF	MIL-HDBK-217F@25°C	1000	--	--	K hours
Case Material	Plastic(UL94-V0)				
Weight		--	5	--	g

ENVIRONMENTAL SPECIFICATIONS

Item	Test Conditions	Min.	Typ.	Max.	Unit
Storage Humidity	Non condensing	--	--	95	%
Operating Temperature	Power derating (above 71 °C)	-40	--	85	°C
Storage Temperature		-55	--	125	
Temp. rise at full load	Ta=25°C	--	15	--	
Lead Temperature	1.5mm from case for 10 seconds	--	--	300	
Cooling		Free air convection			

EMC SPECIFICATIONS

EMI	CE	CISPR22/EN55022 CLASS A (External Circuit Refer to Figure1-②)			
EMS	ESD	IEC/EN61000-4-2	Contact ±4KV	perf. Criteria B	
	EFT	IEC/EN61000-4-4	±2KV	perf. Criteria B (External Circuit Refer to Figure 1-①)	
	Surge	IEC/EN61000-4-5	±2KV	perf. Criteria B (External Circuit Refer to Figure 1-①)	

EMC RECOMMENDED CIRCUIT

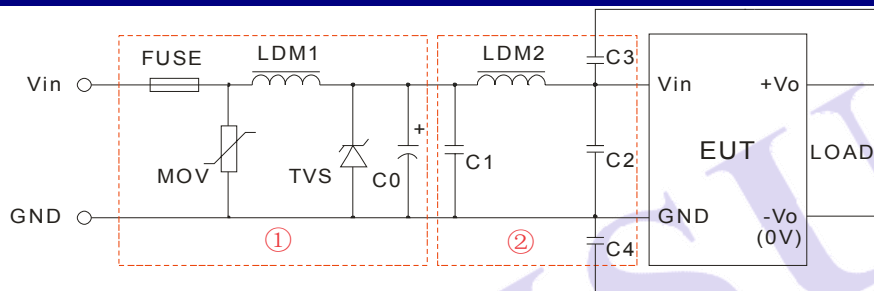

(Figure1)

WRE_CKS-1W recommended external circuit parameters:

Model		Vin: 5V	Vin: 12V	Vin: 24V	Vin: 48V
EMS	FUSE	Choose according to practical input current			
	MOV	--	--	10D560K	10D101K
	LDM1	--	--	56μH	56μH
	TVS	SMCJ13A	SMCJ28A	SMCJ48A	SMCJ90A
	C0	680μF/16V	680μF/25V	120μF/50V	120μF/100V
EMI	C1	4.7μF/50V	4.7μF/50V	4.7μF/50V	4.7μF/100V
	LDM2	4.7μH	6.8μH	4.7μH	4.7μH
	C2	--	--	--	2.2μF/100V
	C4	--	--	100pF/3KV	1000pF/3KV

WRF_CKS-1W recommended external circuit parameters:

Model		Vin: 5V	Vin: 12V	Vin: 24V	Vin: 48V
EMS	FUSE	Choose according to practical input current			
	MOV	--	--	10D560K	10D101K
	LDM1	--	--	56μH	56μH
	TVS	SMCJ13A	SMCJ28A	SMCJ48A	SMCJ90A
	C0	680μF/16V	680μF/25V	120μF/50V	120μF/100V
EMI	C1	4.7μF/50V	4.7μF/50V	4.7μF/50V	4.7μF/100V
	LDM2	4.7μH	4.7μH	4.7μH	4.7μH
	C2	--	1μF/50V	1μF/50V	2.2μF/100V
	C3	--	--	1000pF/3KV	1000pF/3KV
	C4	1000pF/3KV	--	1000pF/3KV	1000pF/3KV

Note: 1. In Figure 1, part① is EMS Recommended external circuit, part② is EMI recommended external circuit. Choose according to requirements.
2. If there is no recommended parameters, the model no require the external component.

EMC RECOMMENDED CIRCUIT PCB LAYOUT

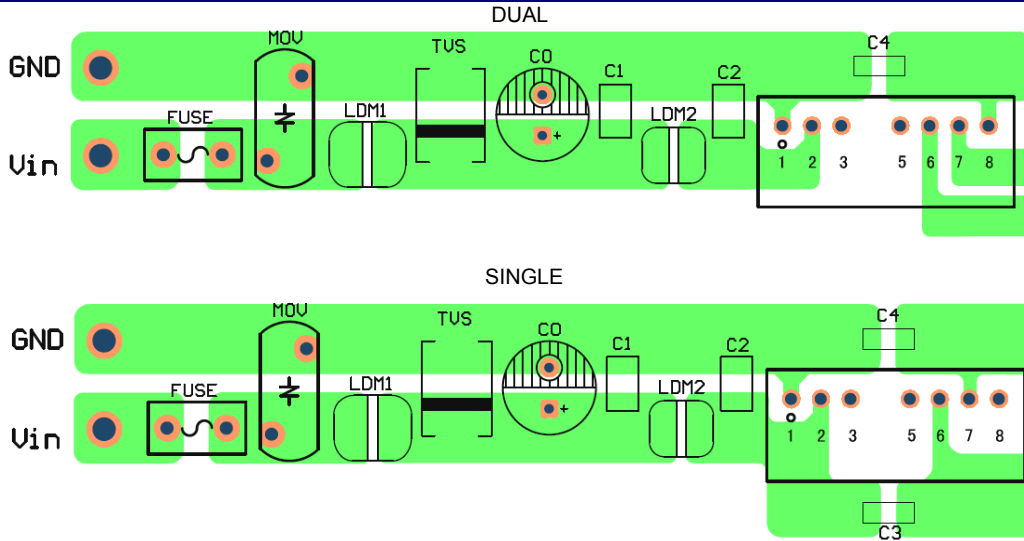

(Figure 2)

PRODUCT TYPICAL CURVE

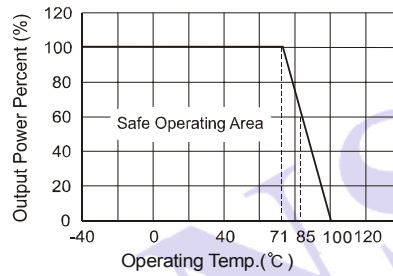

Efficiency VS Input Voltage (Full load)

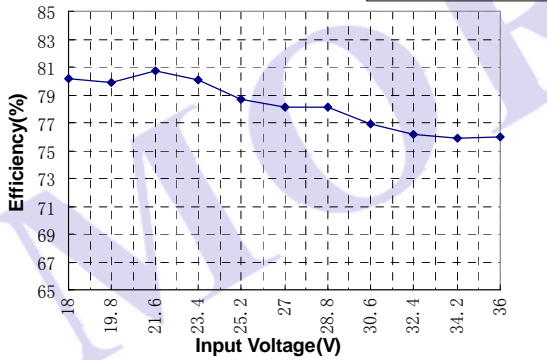

Efficiency VS Input Voltage (Full load)

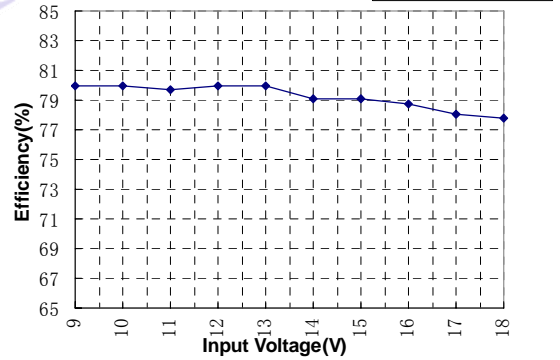

Efficiency VS Output Load curve (Vin=Vin-nominal)

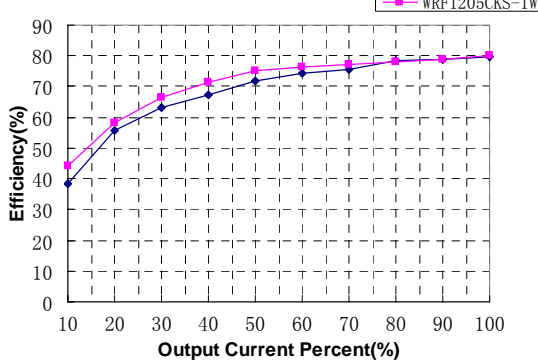

Efficiency VS Output Load curve (Vin=Vin-min)

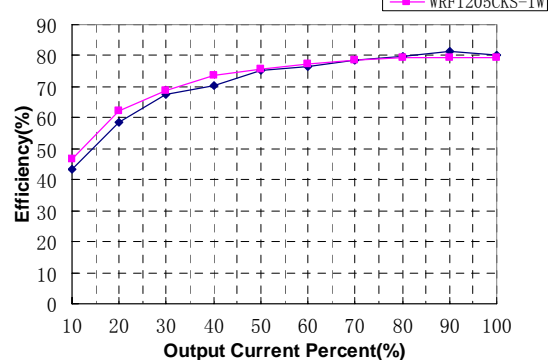

OUTLINE DIMENSIONS, RECOMMENDED FOOTPRINT & PACKAGING

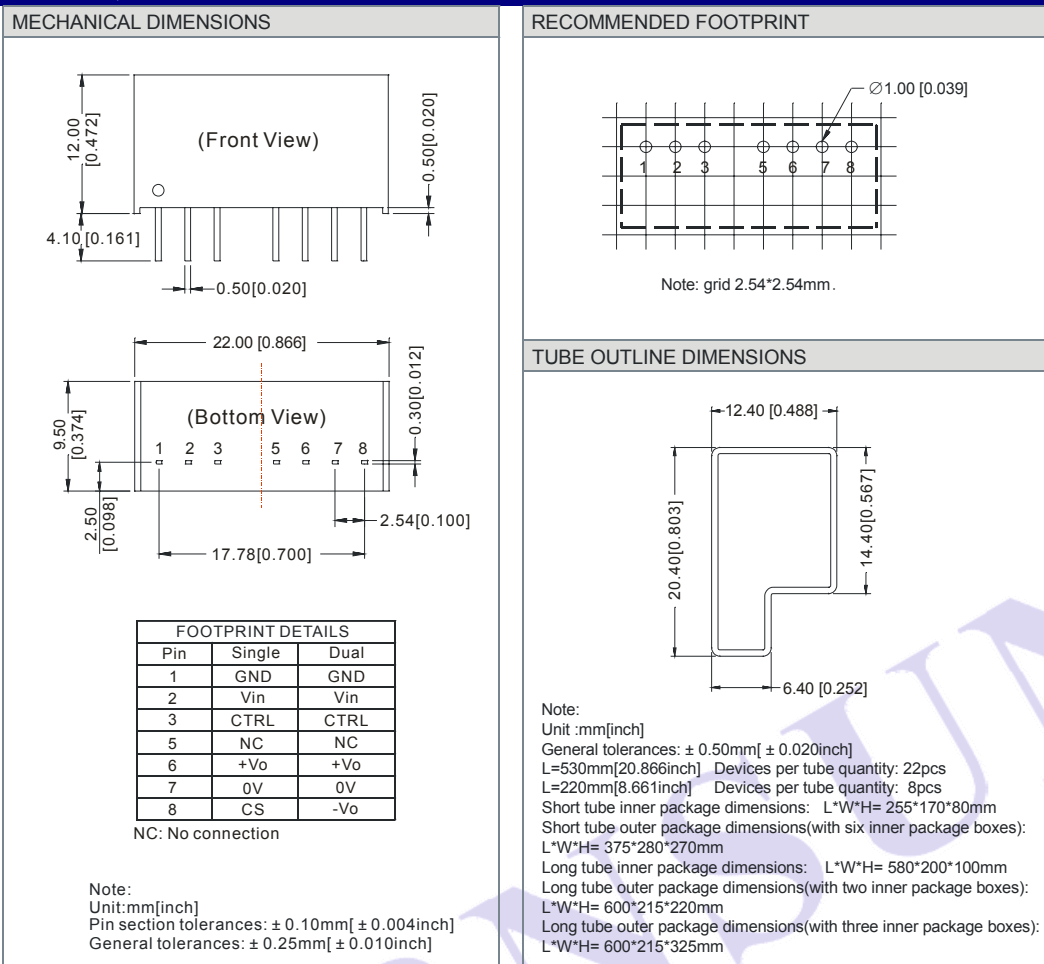

TEST CONFIGURATIONS

Input Reflected-Ripple Current Test Setup

Input reflected-ripple current is measured with an inductor L_{in} and C_{in} to simulate source impedance.

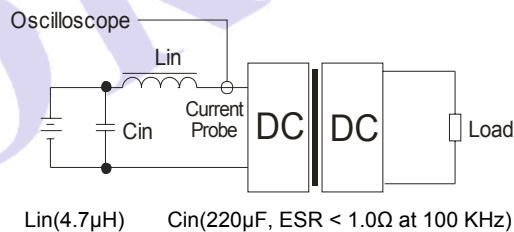

DESIGN CONSIDERATIONS

1) Requirement on output load

To ensure this module can operate efficiently and reliably, During operation, the minimum output load **could not be less than 10% of the full load**. If the actual output power is very small, please connect a resistor with proper resistance at the output end in parallel to increase the load, or use our company's products with a lower rated output power.

2) Overload Protection

Under normal operating conditions, the output circuit of these products has no protection against overload. The simplest method is add a circuit breaker to the circuit.

3) Recommended circuit

If you want to further decrease the input/output ripple, an "LC" filtering network may be connected to the input and output ends of the DC/DC converter, see (Figure 3).

It should also be noted that the inductance and the frequency of the "LC" filtering network should be staggered with the DC/DC frequency to avoid mutual interference. However, the capacitance of the output filter capacitor must be proper. If the capacitance is too big, a startup problem might arise. For every channel of output, provided the safe and reliable operation is ensured, the greatest capacitance of its filter capacitor must less than the Max. Capacitive Load.

General: C_{in} : 5V&12V 100 μ F
 24V&48V 10 μ F
 C_{out} : 47 μ F (Typ.)
 L_{in} : 4.7 μ H~120 μ H
 L_{out} : 2.2 μ H~10 μ H
 C_s : 10 μ F~22 μ F



(Figure 3)

4) CTRL Terminal

When open or high impedance, the converter work well; When this pin is 'high level'; the converter shutdown; It should be note that the input current should between 5-10mA,exceeding the maximum 20mA will cause permanence damage to the converter. The value of R can be derived as follows:

$$R = \frac{V_c - V_D - 1.0}{I_c}$$

5) Input current

Nominal input voltage range.The input current of the power supply must be sufficient to the startup current (I_p) of the DC/DC module(Figure 4).

General: $I_p \leq 1.4 \cdot I_{in-max}$.

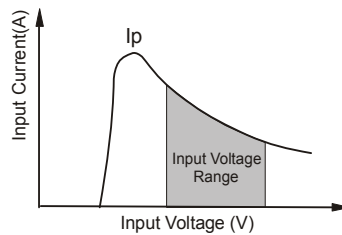

(Figure 4)

6) Cannot use in parallel and hot swap

Note:

1. The load shouldn't be less than 10%, otherwise ripple maybe increase dramatically. Operation under minimum load will not damage the converter; However, they may not meet all specification listed.
2. Max. Capacitive Load tested at input voltage range and full load.
3. All specifications measured at $T_a=25^\circ\text{C}$, humidity<75%, nominal input voltage and rated output load unless otherwise specified.
4. In this datasheet, all the test methods of indications are based on corporate standards.
5. Only typical models listed, other models may be different, please contact our technical person for more details.
6. Our company offer custom products.
7. Specifications subject to change without notice.

MORNSUN Science & Technology Co.,Ltd.

Address: No. 5, Kehui St. 1, Kehui development center, Science Ave., Guangzhou Science City, Luogang district, Guangzhou,P.R.China.

Tel: 86-20-38601850

Fax:86-20-38601272

[Http://www.mornsun-power.com](http://www.mornsun-power.com)